

2ACm Centrifugal multistage cast iron pump

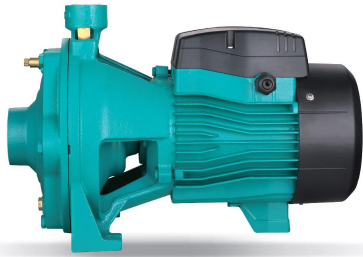

Application

- Transfer of clear water or other liquids chemically and physically comparable to water
- Suitable for industrial use and water supply, fire system, garden irrigation, long distance water transfer, air conditioning system, circulation and overpressure for hot and cold water, etc ...

Pompe

- Special anti-rust treatment (cataphoresis) for the cast iron pump body and the lantern
- AISI 304 stainless steel shaft
- Maximum liquid temperature: +40°C
- Maximum suction height: 8 m

Moteur

- Integrated thermal protection for single-phase motors
- Insulation class: F
- Protection class: IPX4
- Maximum ambient temperature: +40°C
- IE2 motor (three-phase, motor > 0.75 kW)

Identification codes

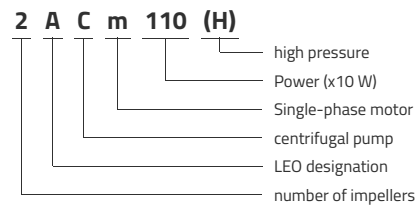

Technical data

MODEL	kW	Q (m³/h)	0	1.2	1.8	2.4	3	3.6	4.2	4.8	5.4	6	6.6	7.2	8.4	9.6	10.8	12	15
		Q (l/min)	0	20	30	40	50	60	70	80	90	100	110	120	140	160	180	200	250
2ACm75	0.75	45	42.5	40	37	33.5	28.5	23	15										
2AC75	0.75	45	42.5	40	37	33.5	28.5	23	15										
2ACm110	1.1	47	46	45	44	43	41.5	40	38	35.5	33	30.5	28	22					
2AC110	1.1	47	46	45	44	43	41.5	40	38	35.5	33	30.5	28	22					
2ACm150	1.5	57.5	55.5	54.5	53.5	52	50.5	49	47	44.5	41.5	38.5	35	28	20				
2AC150	1.5	57.5	55.5	54.5	53.5	52	50.5	49	47	44.5	41.5	38.5	35	28	20				
2ACm150H	1.5	63.5	60.5	58.5	56.5	54	51.5	48.5	45	41	37.5	33.5	29						
2AC150H	1.5	63.5	60.5	58.5	56.5	54	51.5	48.5	45	41	37.5	33.5	29						
2AC220	2.2	65	63	62	61	59.5	58	56	54	51.5	49	46	43	36	28.5	20.5			
2ACm300H	3				62	61	60	59	58	56.5	55	53.5	52.5	48.5	44.5	40	35	21	
2AC300H	3				67	66	65	64	63	62	61	59.5	59	55.5	52	49	45	33	
2AC400H	4					79.5	78.5	77.5	76.5	75.5	74.5	73.5	72	71	67.5	64.5	61	57	45.5

Dimensions

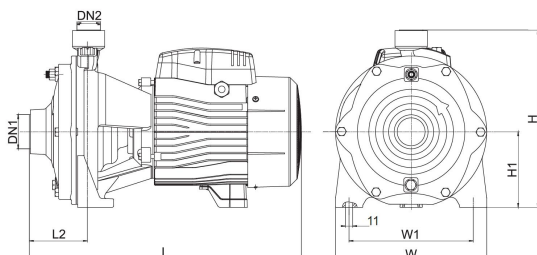

MODEL	DN1	DN2	L	L2	H	H1	W	W1
2ACm75	1¼	1	336	72	231	100	181	145
2AC75	1¼	1	336	72	231	100	181	145
2ACm110	1½	1	379	71	225	93	200	162
2AC110	1½	1	379	71	225	93	200	162
2ACm150	1½	1	400	80	262	112	225	185
2AC150	1½	1	400	80	262	112	225	185
2ACm150H	1½	1	400	80	262	112	225	185
2AC150H	1½	1	400	80	262	112	225	185
2AC220	1½	1	400	80	262	112	225	185
2ACm300H	1½	1¼	480	63	311	132	281	234
2AC300H	1½	1¼	480	63	311	132	281	234
2AC400H	1½	1¼	480	63	311	132	281	234

Hydraulic performance

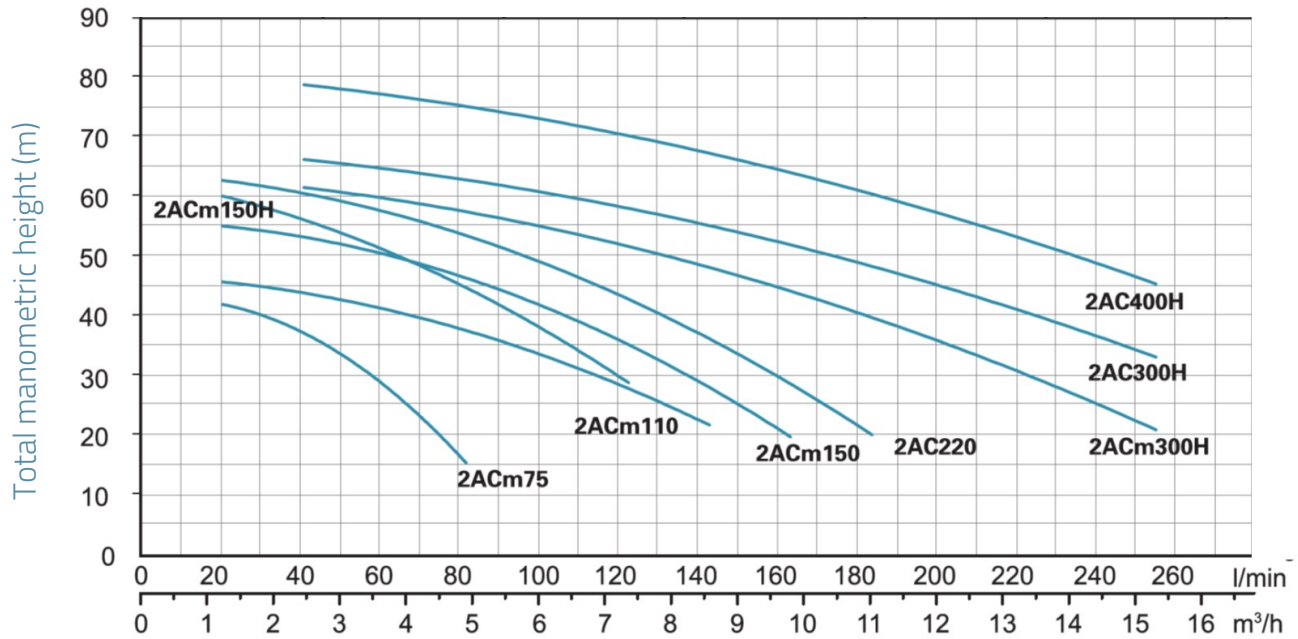

Exploded view

No.	Type	Materials
1	Drain plug	brass HPb59-1
2	Pump body	cast iron HT200
3	O-ring	nitrile rubber (NBR)
4	Impeller	stainless steel AISI 304 / cast iron HT200
5	Diffuser	cast iron HT200
6	Mechanical seal	carbon / ceramic
7	Lantern	cast iron HT200
8	Oil seal	
9	Bearing	
10	Rotor	
11	Stator	
12	Rear cover	cast aluminum ZL102
13	Fan	polypropylene
14	Fan cover	polypropylene
15	Terminal board	polycarbonate
16	Capacitor	
17	Electric box cover	PA6 resin

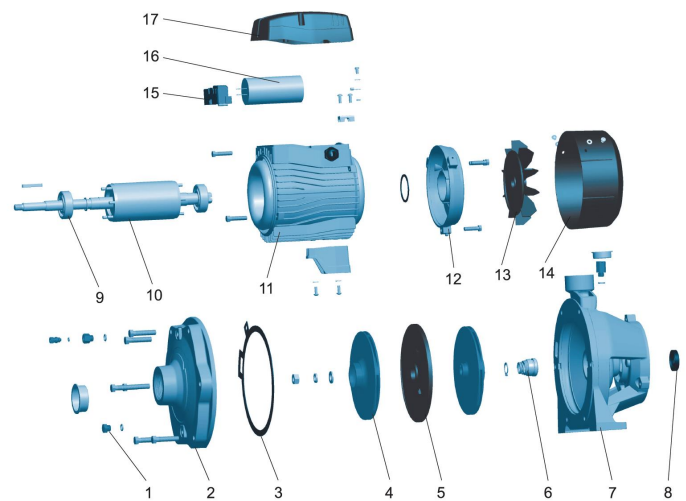

Packaging

MODEL	Weight (kg)	Length L (mm)	Width W (mm)	Height H (mm)
2ACm75	16.8	385	215	270
2AC75	16.8	385	215	270
2ACm110	21	430	235	275
2AC110	21	430	235	275
2ACm150	27.5	445	255	300
2AC150	27.5	445	255	300
2ACm150H	27.8	440	254	299
2AC150H	27.8	440	254	299
2AC220	27.5	445	255	300
2ACm300H	51.9	542	330	346
2AC300H	51.9	542	330	346
2AC400H	52.4	542	330	346

